

Zoom-Desk Installation Manual

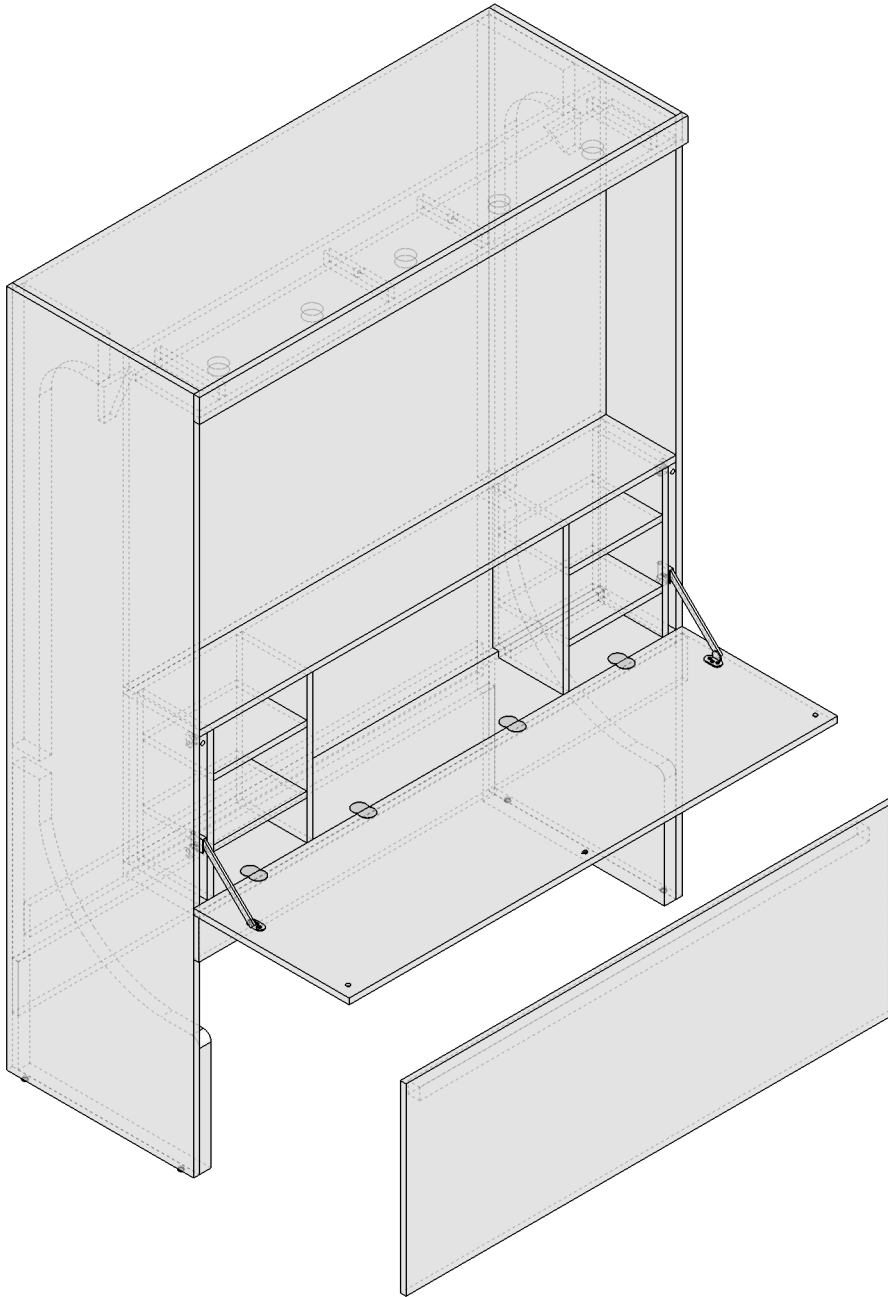

INSTRUCTIONS:

Place Right Panel vertically on the long unfinished edge.
The quoter turn screws should be on the right side of the panel

NOTE: A SECOND PERSON IS REQUIRED FOR THIS STEP

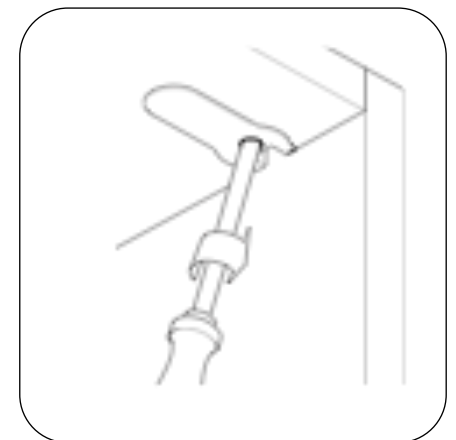
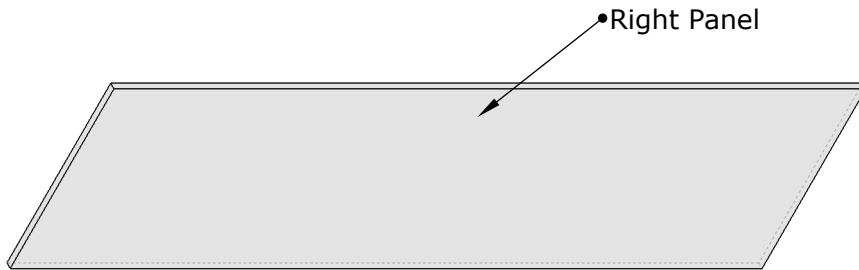

INSTRUCTIONS:

Place Top Panel on the unfinished edge and slide it on to the quarter-turn attachments. Push the top panel Down in to place. You may need to tap the Top Panel with the mallet to secure it in place.

Tighten the fasteners with your Screwdriver

NOTE: A SECOND PERSON IS REQUIRED FOR THIS STEP

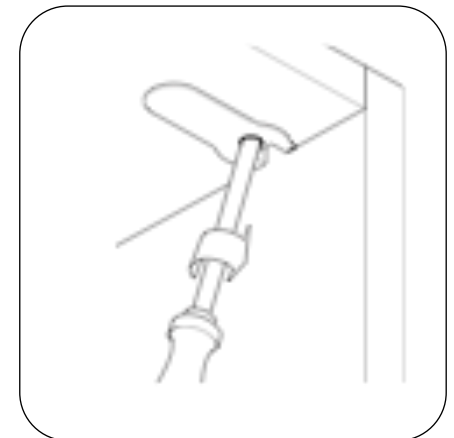
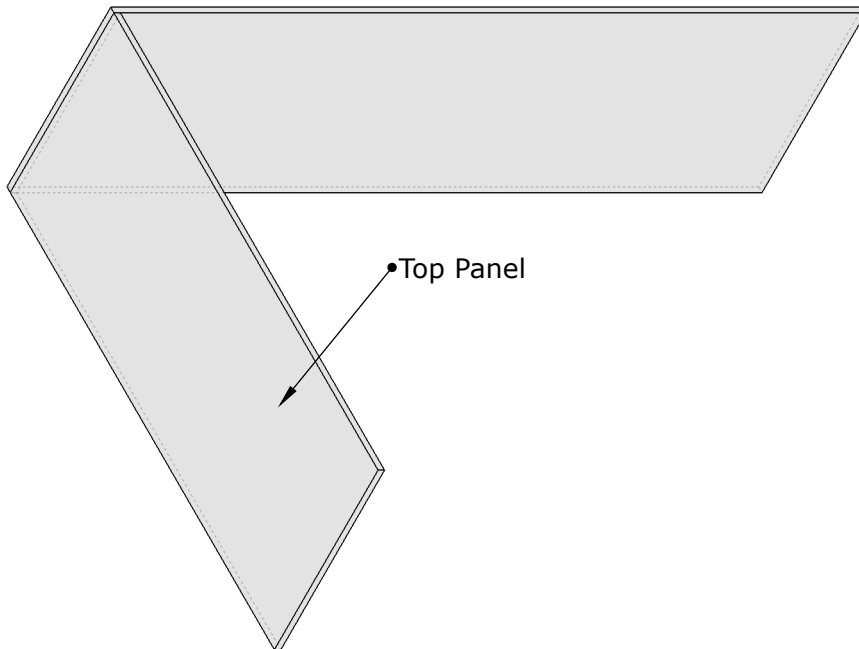

INSTRUCTIONS:

Place the Left Panel on the unfinished edge and slide it on to the quarter-turn attachments. Push the top panel Down in to place. You may need to tap the top panel with the mallet to secure it in place.
Tighten the fasteners with your Screwdriver

NOTE: A SECOND PERSON IS REQUIRED FOR THIS STEP

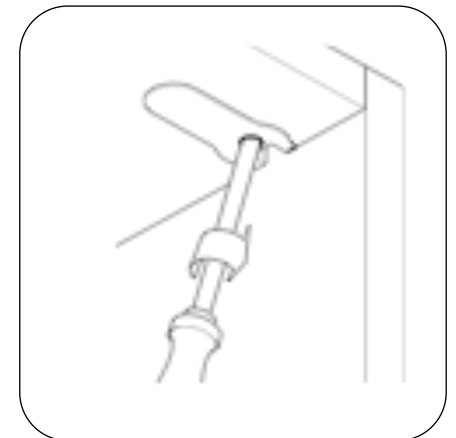
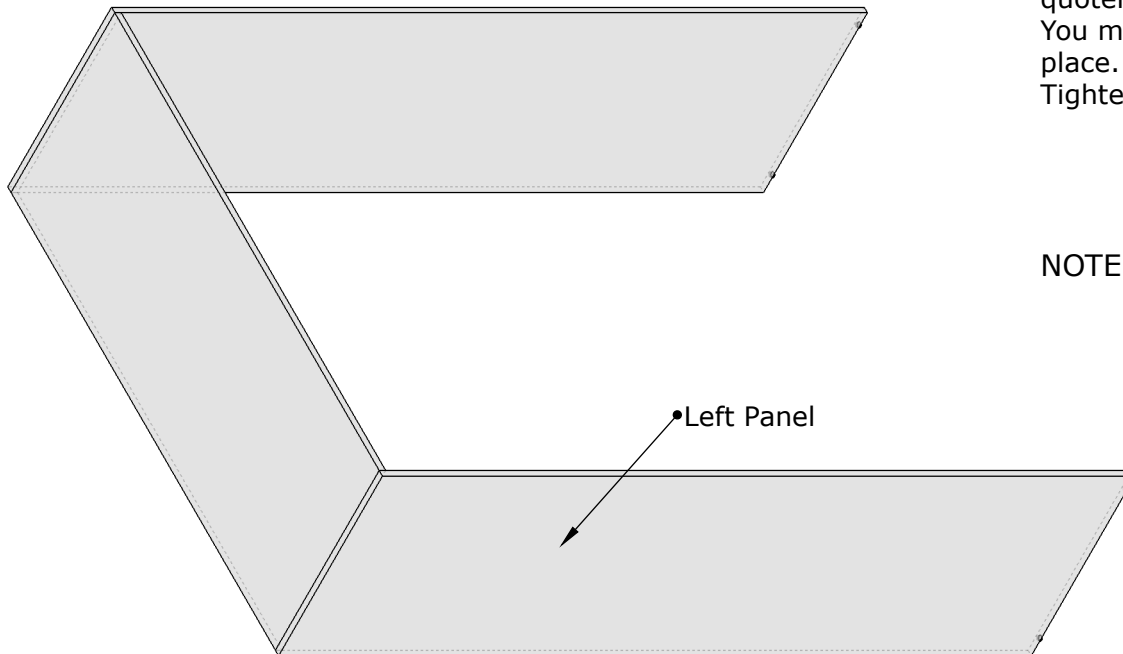

INSTRUCTIONS:

Carefully slide the TV Shelf Panel between the two sides panels. Push the Tv panel Down in to place. You may need to tap the top panel with the mallet to secure it in place.

Tighten the front fasteners with your screwdriver, do not tighten the back fastners yet.

NOTE: A SECOND PERSON IS REQUIRED FOR THIS STEP

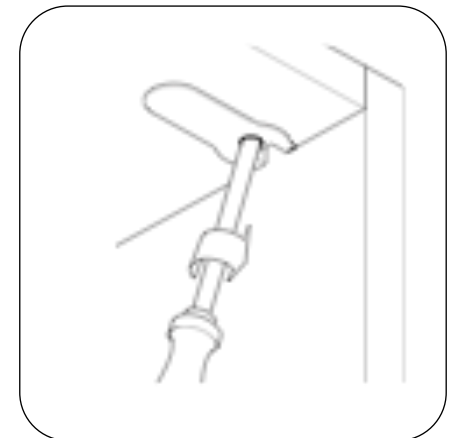
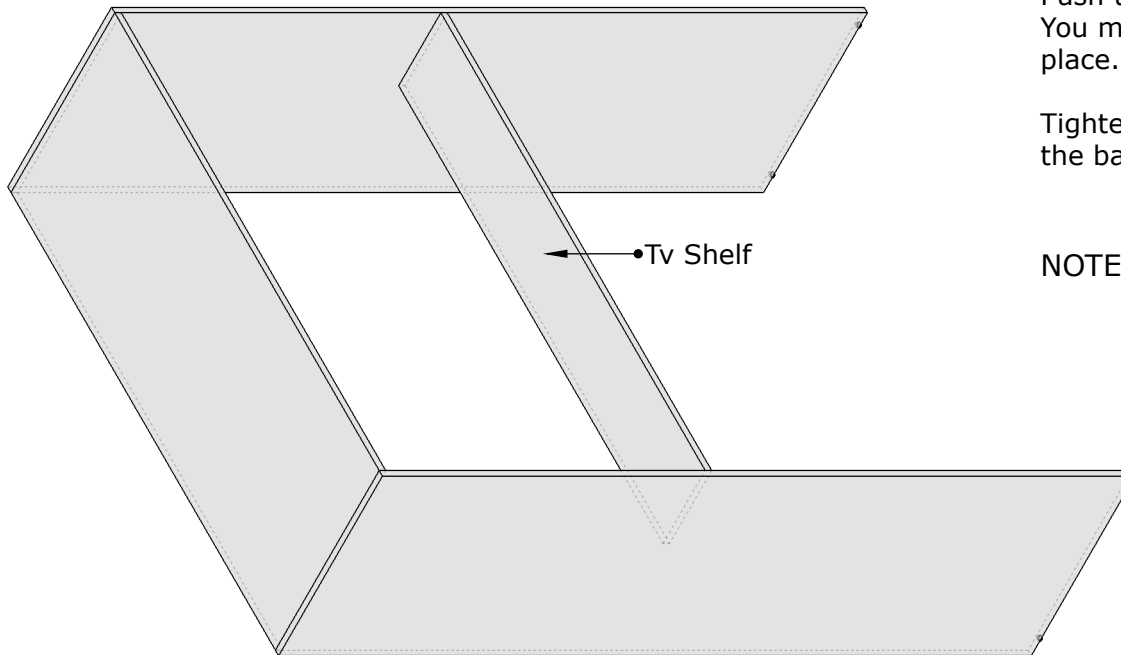

INSTRUCTIONS:

Carefully slide the Desk Shelf Panel between the two sides panels.
Push the Desk Shelf Down in to place.
You may need to tap the top panel with the mallet to secure it in place.
Tighten the fasteners with your Screwdriver

NOTE: A SECOND PERSON IS REQUIRED FOR THIS STEP

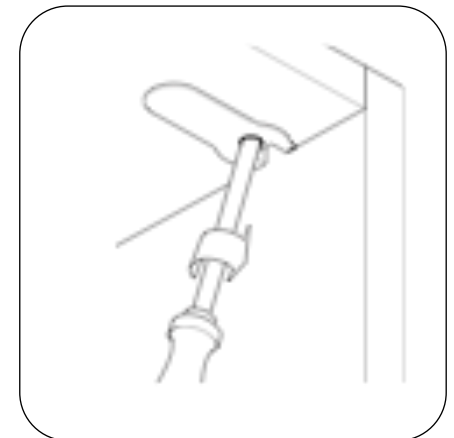
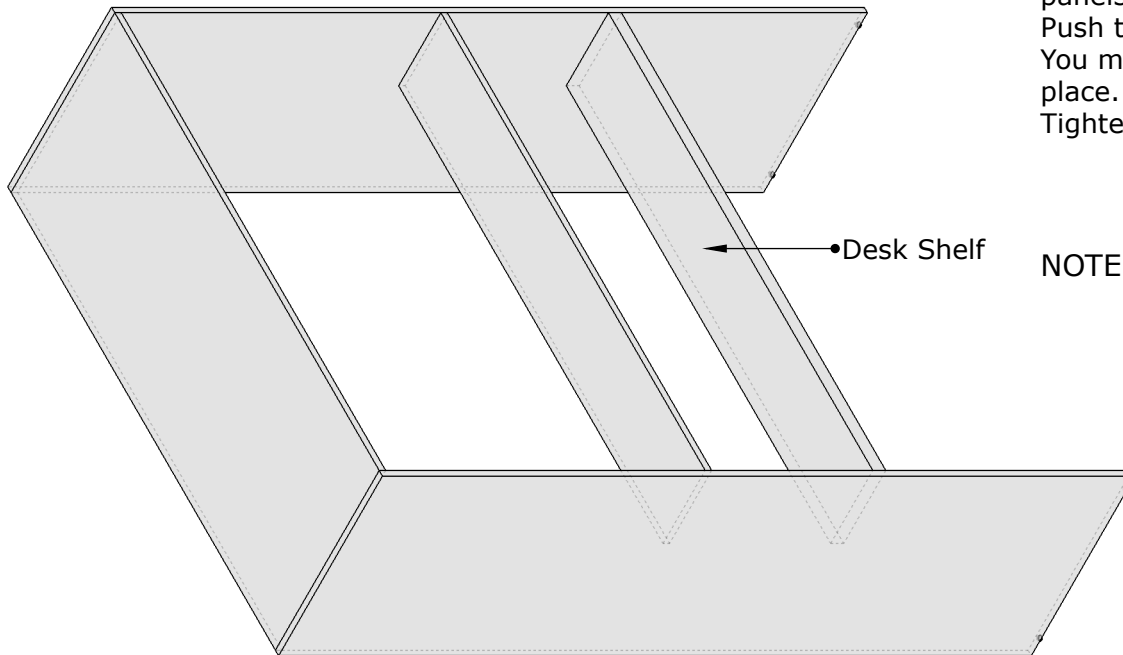

INSTRUCTIONS:

Carefully slide the Desk Panel between the desk and Tv shelf.
Push the Desk Shelf Down in to place.
(TIP: You need to push the the back of Tv shelf to have little more space for the desk panel to slide in correctly)
Gently tap the panel with the mallet to secure it in place.
Tighten all the fasteners with your Screwdriver

NOTE: A SECOND PERSON IS REQUIRED FOR THIS STEP

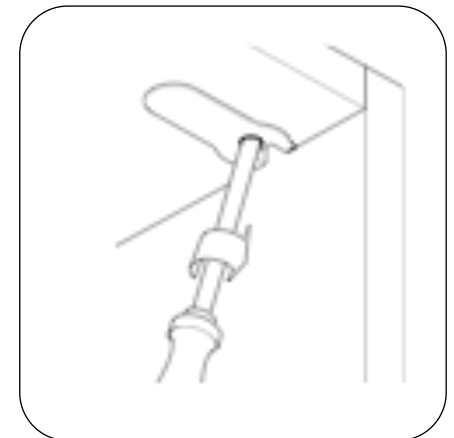
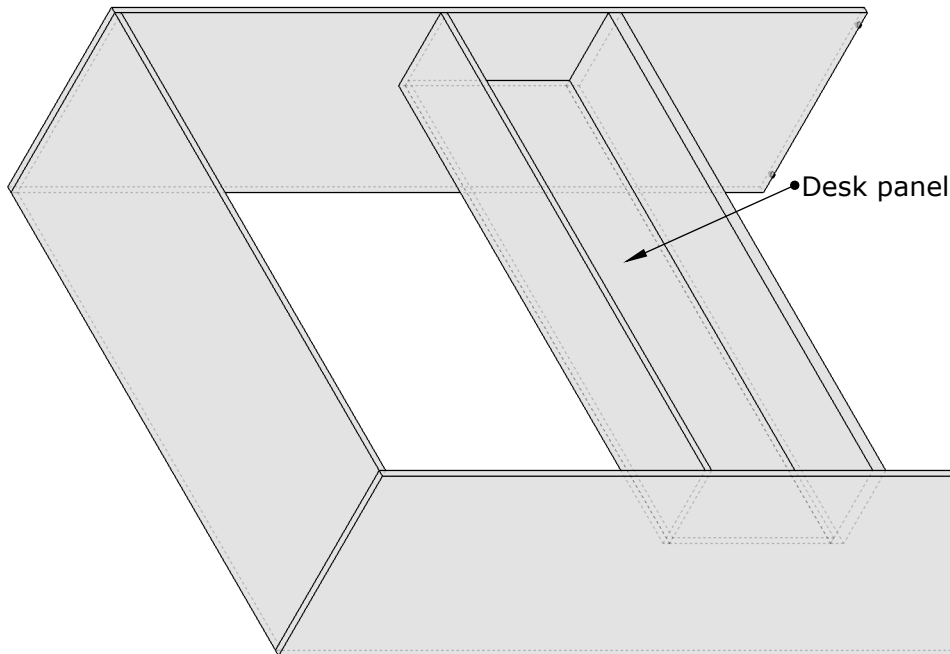

INSTRUCTIONS:

Carefully slide the TV Panel between the Top panel and Tv shelf.
Push the TV Panel down in to place.
Gently tap the panel with the mallet to secure it in place.
Tighten the fasteners with your screwdriver

Once all the fasteners are tight push the cabinet up in to vertical position.

NOTE: A SECOND PERSON IS REQUIRED FOR THIS STEP

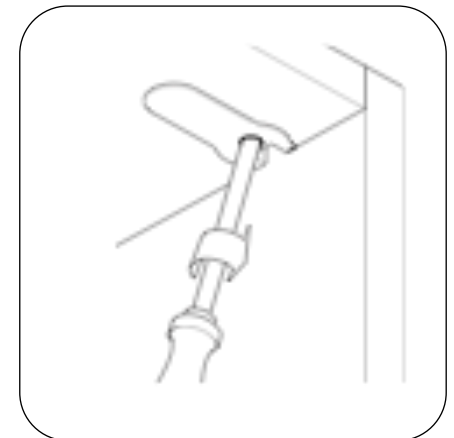
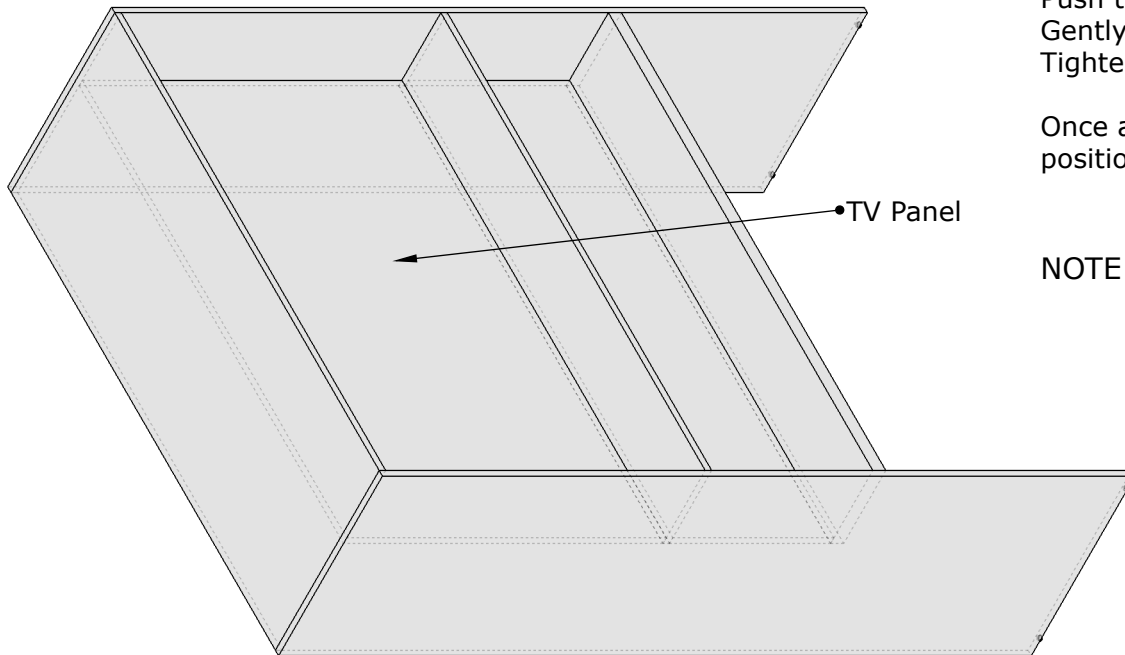

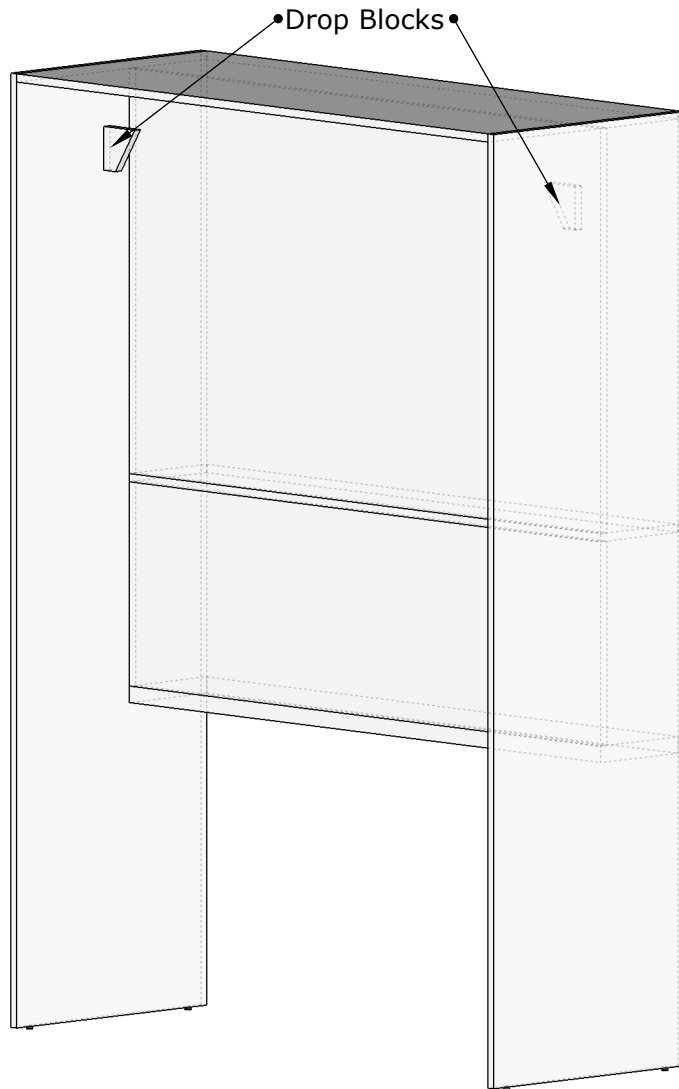

INSTRUCTIONS:

Attach the left and the Right drop blocks. Making sure that they line up to the quarter-turn attachments. You may need to tap it with the mallet to secure it in place. Tighten the fasteners with your screwdriver

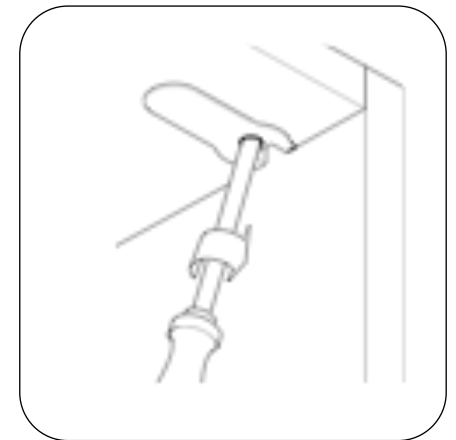

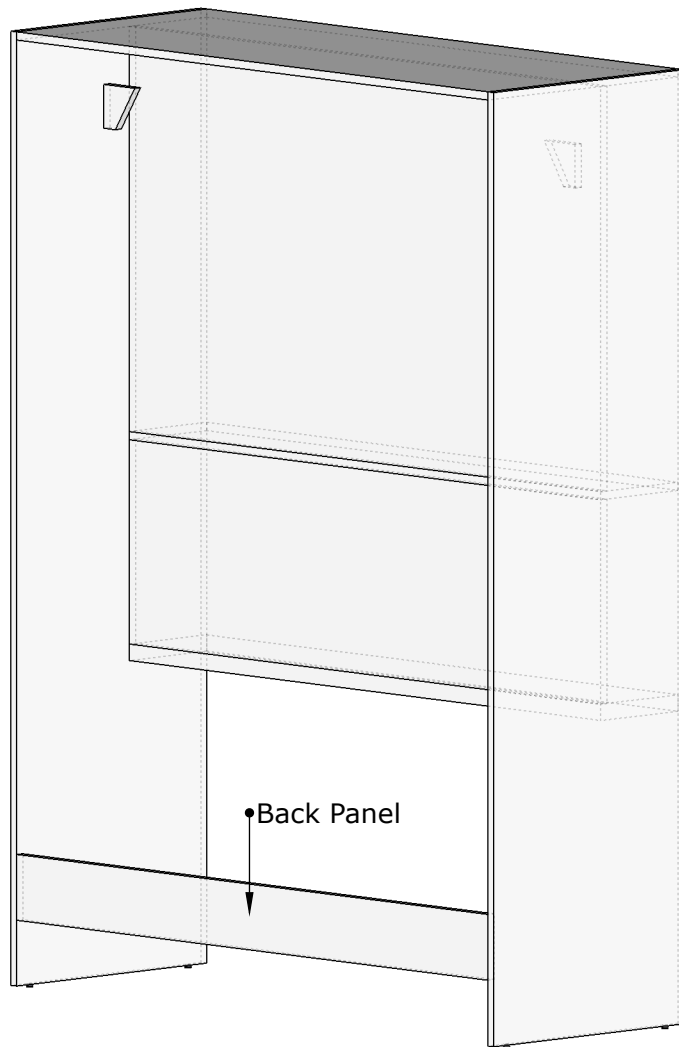

INSTRUCTIONS:

Attach the Back Panel. Making sure that its line up to the quarter-turn attachments. You may need to tap it with the mallet to secure it in place. Tighten the fasteners with your screwdriver

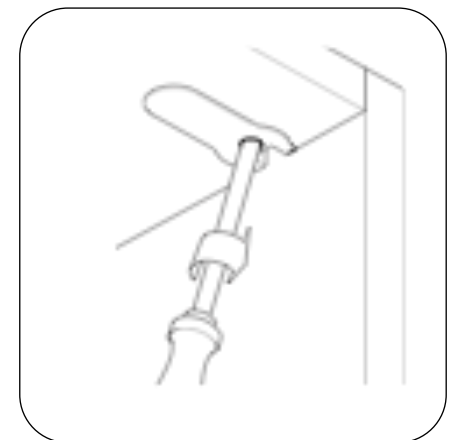

INSTRUCTIONS:

Attach the Lower Bolsters using the 2" screws.
Make sure the bolsters are flush with the front, back and the
bottom of the cabinet.
(TIP: Use shims and carpenter clamps for proper placement)

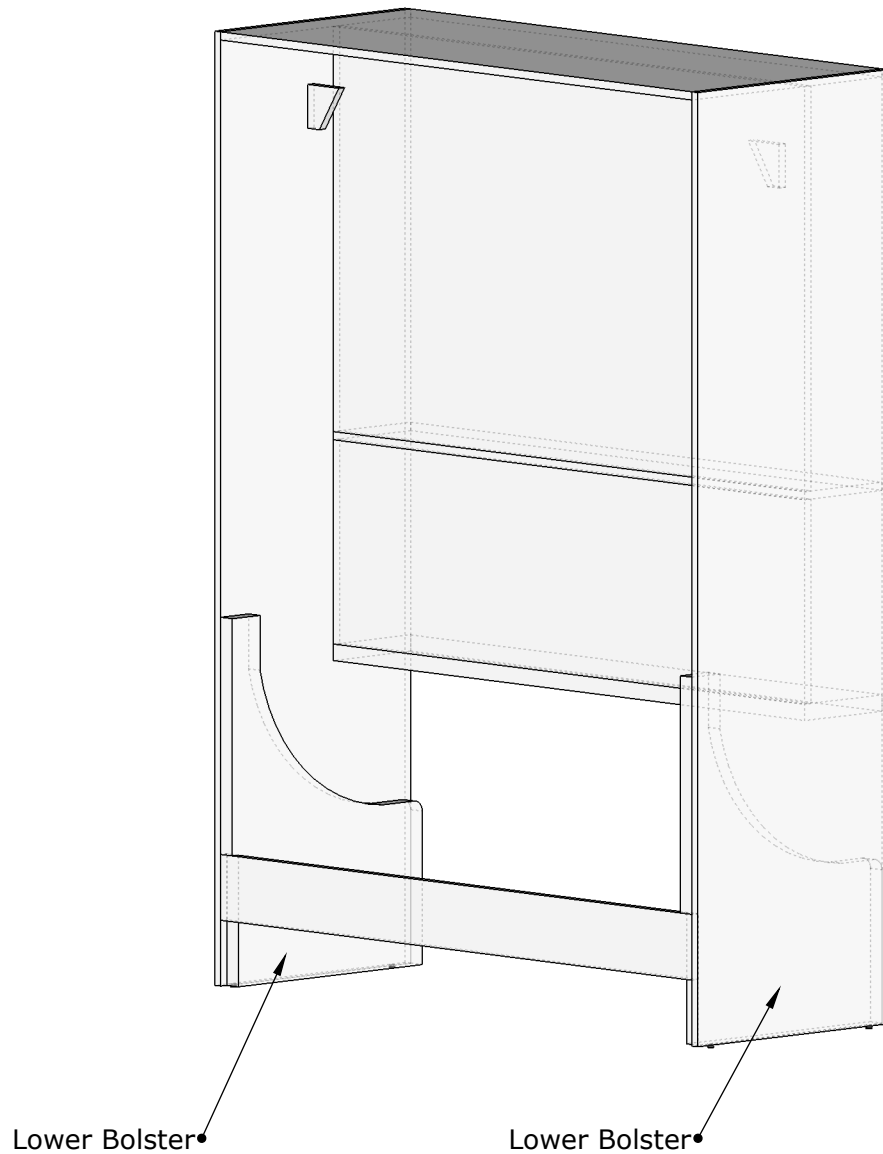



INSTRUCTIONS:

Attach the Lower Bolsters using the 2" screws.
Make sure the bolster are flush with the back of the cabinet.
(TIP: Use carpenter clamps for proper placement)

INSTRUCTIONS:

Attach the Headboard.
Gently push the headboard in to place until the male and female KeKu Clips click together

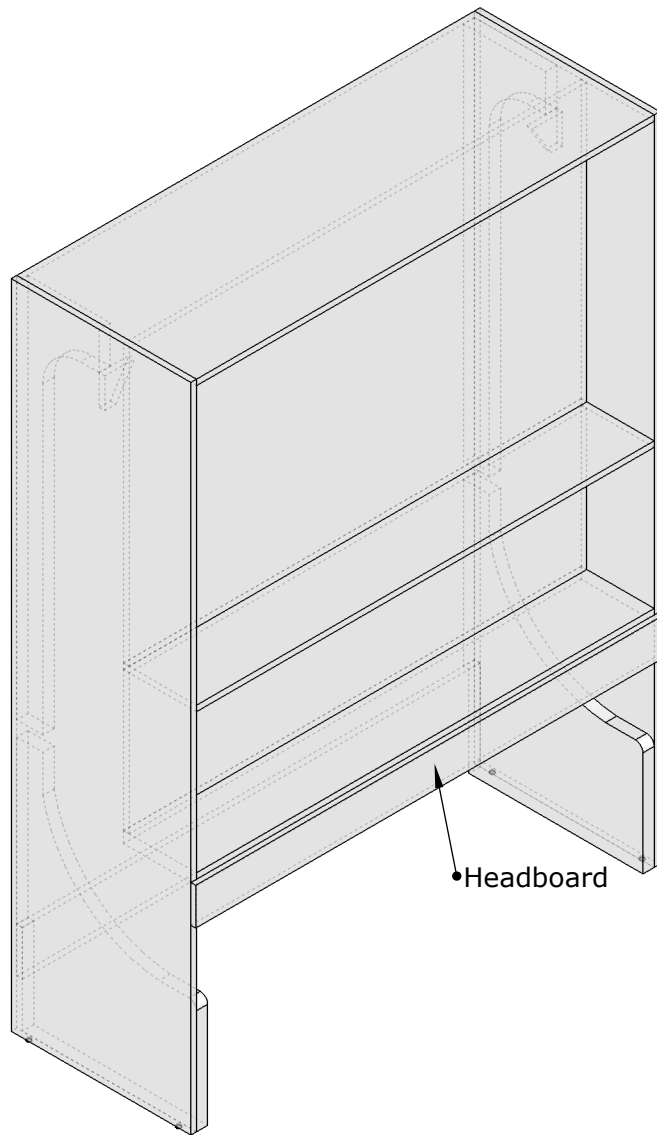

INSTRUCTIONS:

Light Panel (Optional)

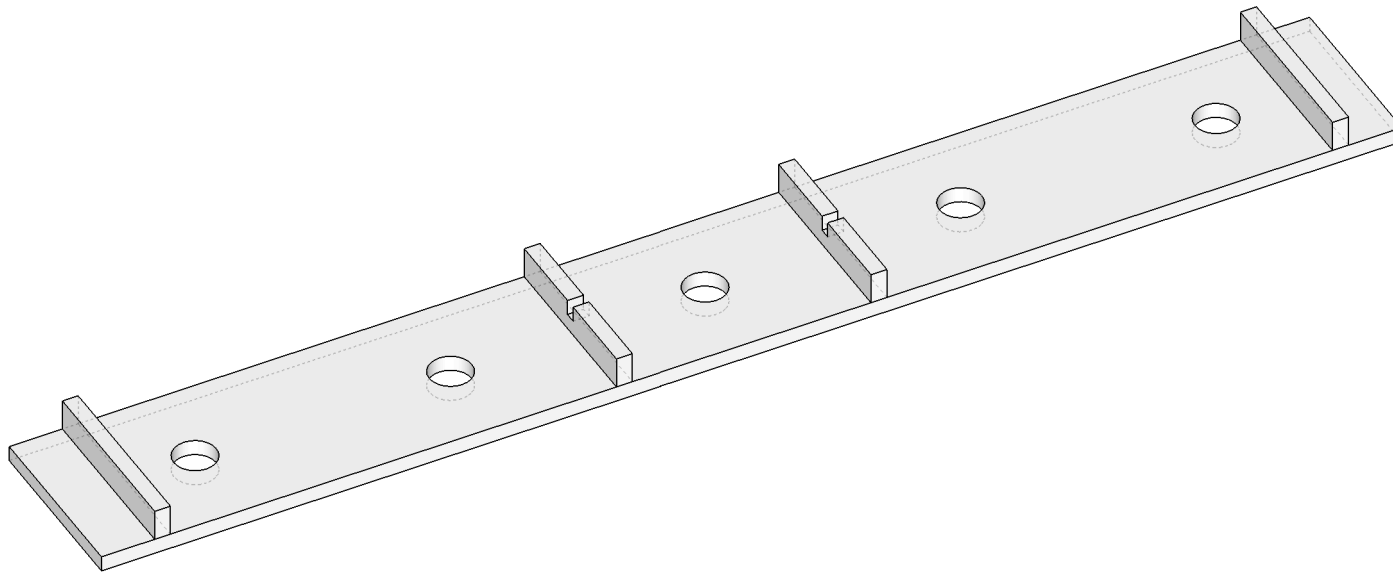

INSTRUCTIONS:

Assemble the Left and the Right desk file organizers.

While holding the side panels carefully slide the top shelf, push it down and tighten the quoters-turn fasteners. Now slide the bottom shelf and tighten the quoters-turn fasteners.

Repeat the whole process for the second shelf.

TIP: One side shelf have a notch for the power cord.

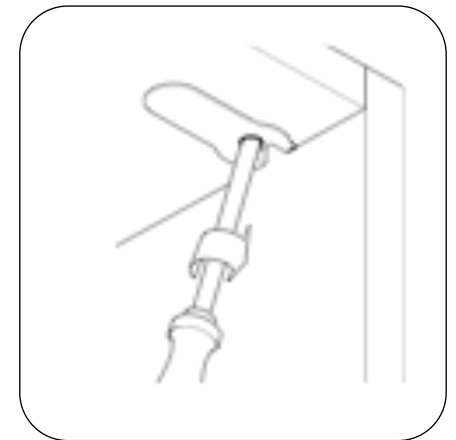
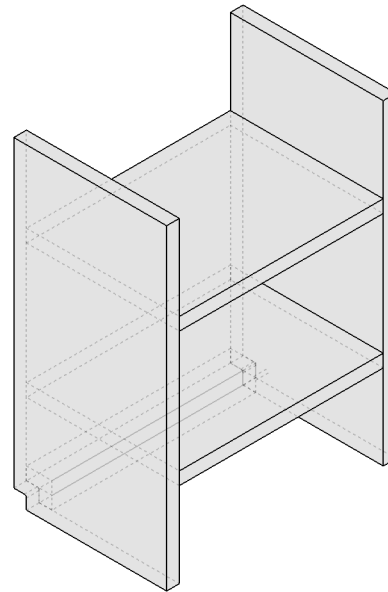
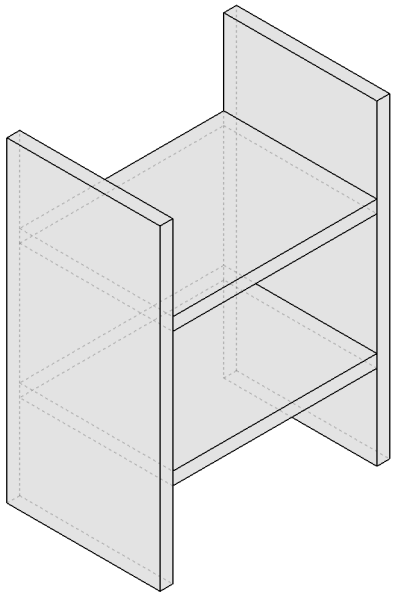

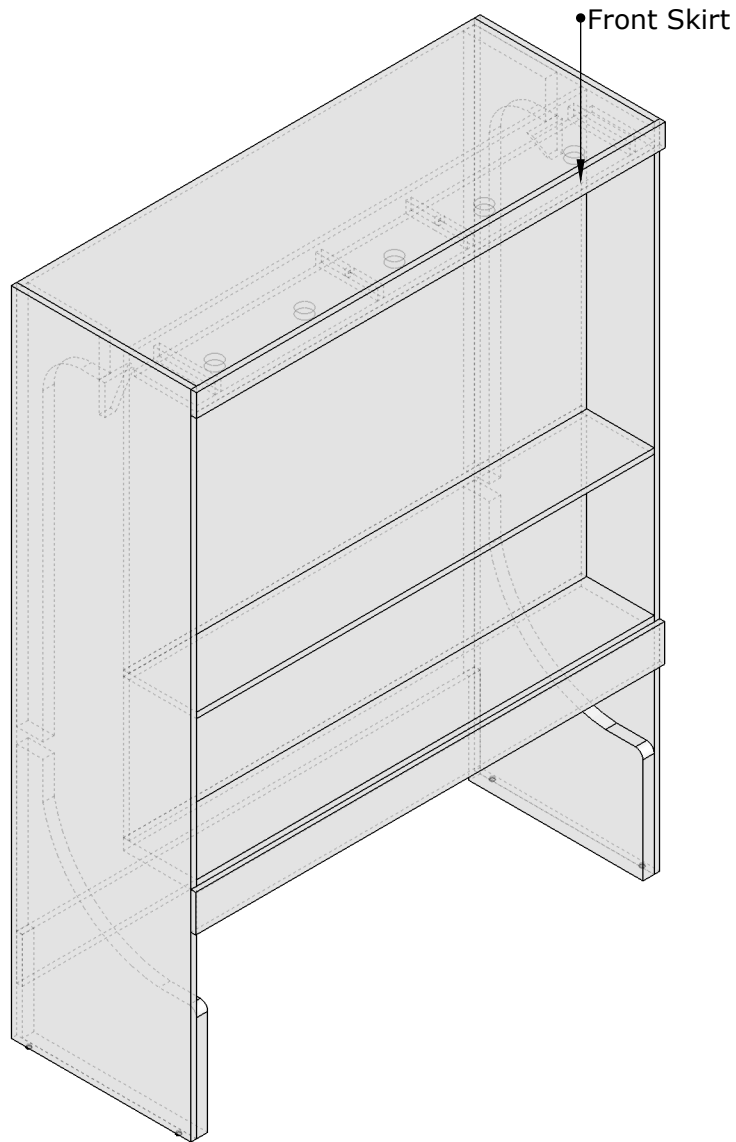

INSTRUCTIONS:

Attach the Front Skirt.
Gently push the Front Skirt in to place until the male and female KeKu Clips click together

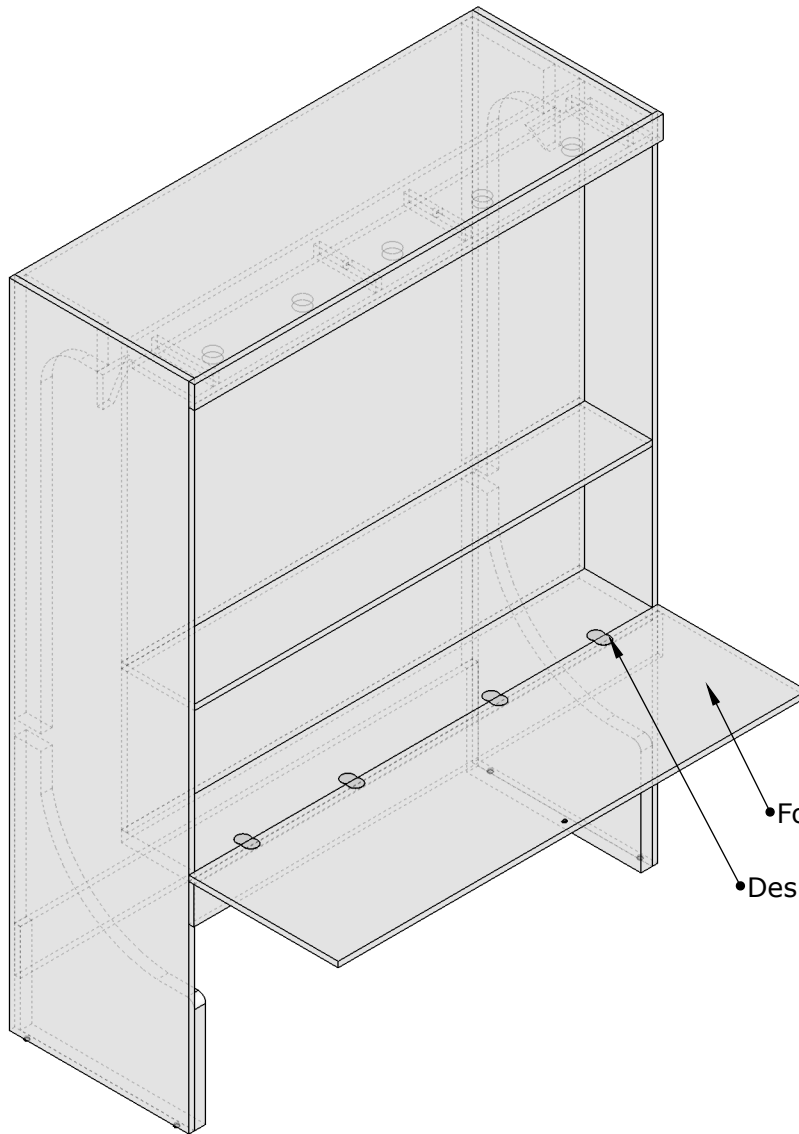

INSTRUCTIONS:

Attach the Fold Down Secretary Desk.

Attach the desk hinges using included P#1 screws.
TIP: Use Philips Nr.1 tip

NOTE: A SECOND PERSON IS REQUIRED FOR THIS STEP

- Fold down Desk
- Desk Hinge

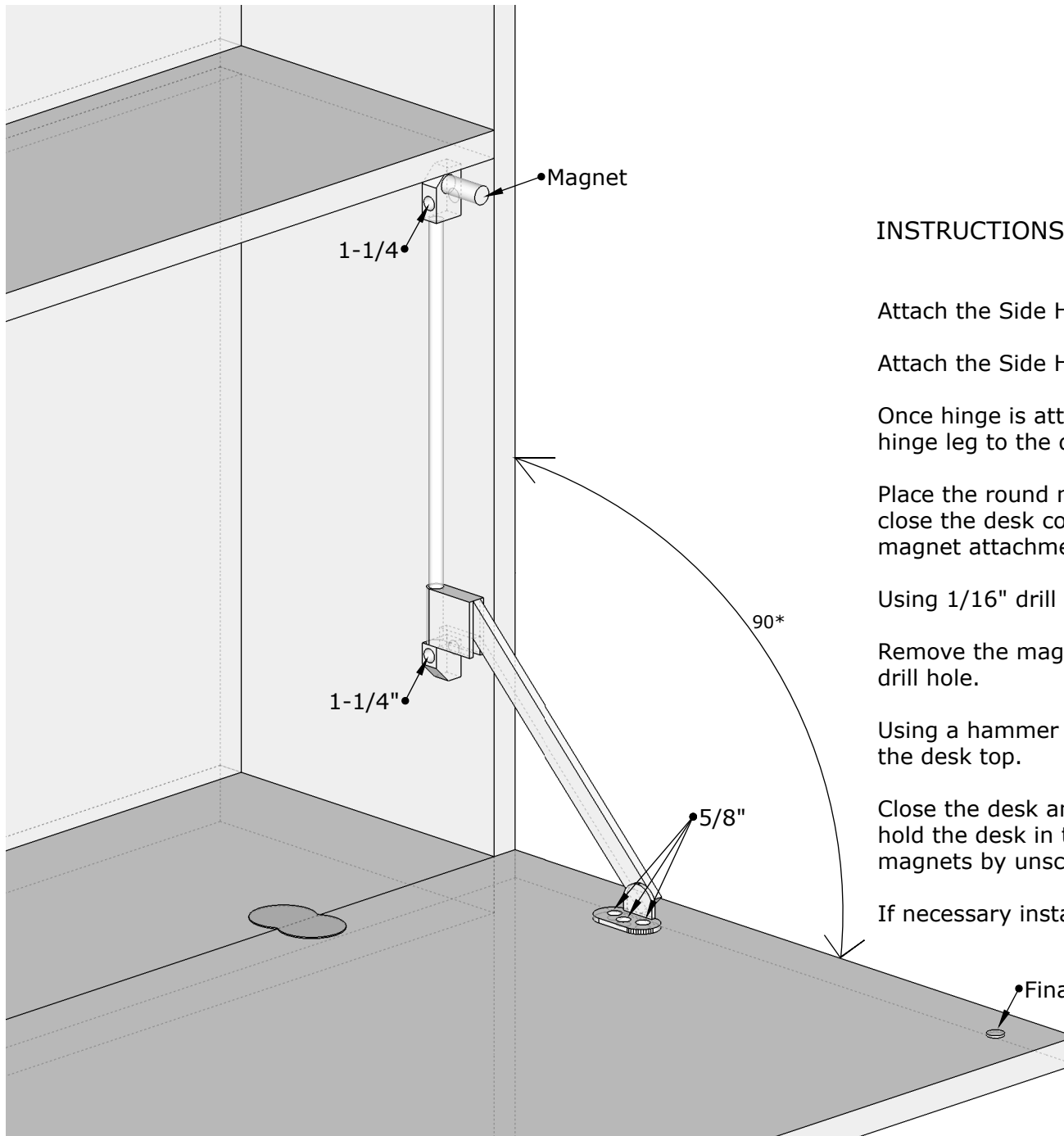

INSTRUCTIONS:

Attach the Side Hinge.

Attach the Side Hinges to the side panel using 1-1/4 screws.

Once hinge is attach properly attached to the side. Attach the hinge leg to the desk using 5/8" screws.

Place the round magnet attachment on to the hinge magnet. close the desk couple of times until you get impression from the magnet attachment tip.

Using 1/16" drill bit drill 1/4" in to the fold down desk panel

Remove the magnet attachment and place it in the previously drill hole.

Using a hammer gently hammer the magnet attachment in to the desk top.

Close the desk and check if the magnets are properly place and hold the desk in the close position. If it is necessary adjust the magnets by unscrewing them from the hinge for better grip.

If necessary install the included lock system.

Final placement of the magnet attachment.

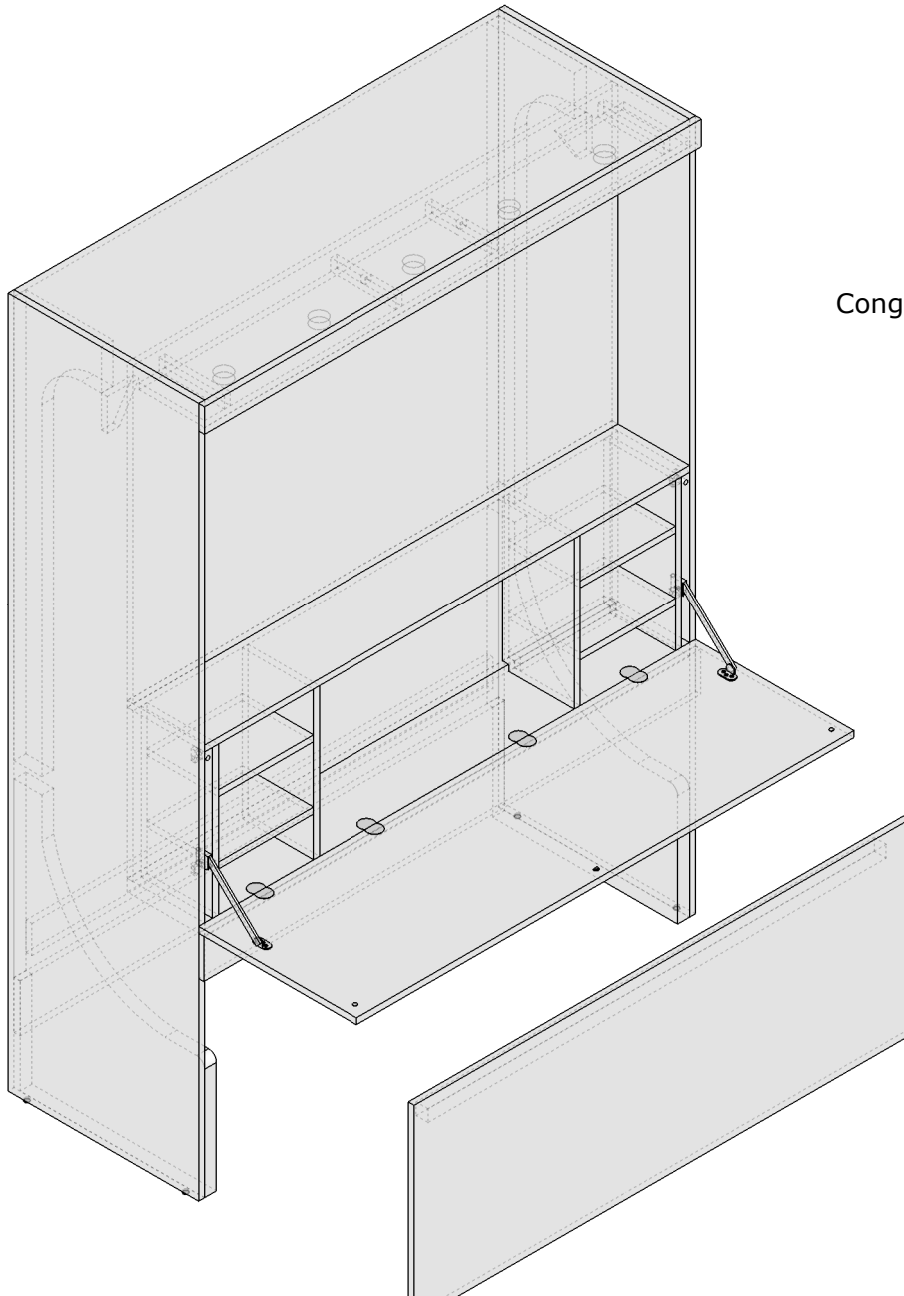

Congratulation you have completed Zoom-Desk Installation